

### The Most Compact and Economical High-Performance, High-Efficiency Centrifugal Compressors

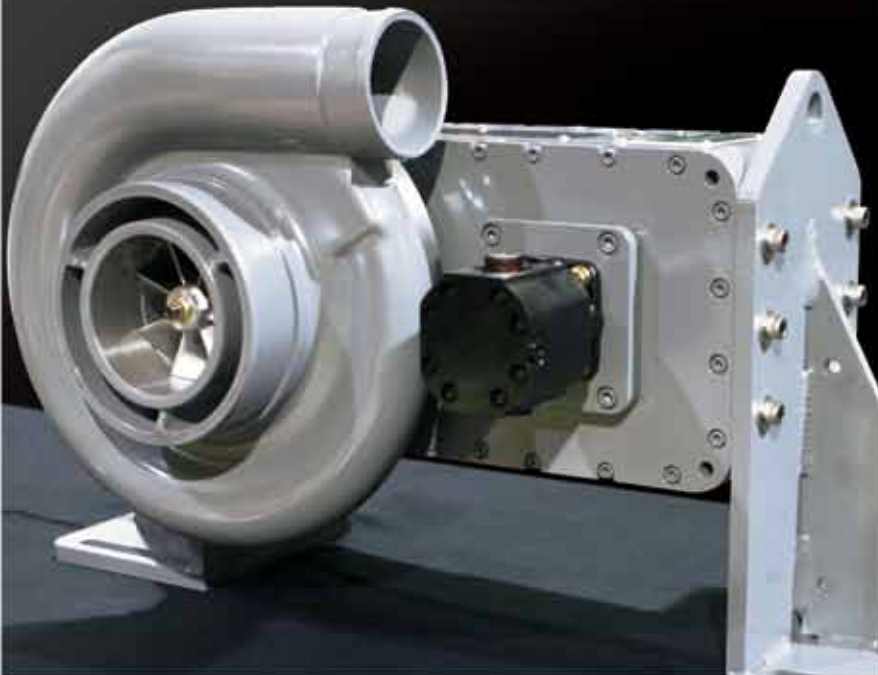

- 4 – 22 psi Operational Range
- 400 – 2,200 CFM at 24/7 Duty Cycles
- 16.65:1 Step-Up Ratio; Integrally Geared
- Low Energy / Power Requirements provide significant energy savings, typically 10 - 35%+
- Quiet operation
- Lower Compressed Air Temperatures vs. Typical Positive-Displacement Blowers
- Compatible / Available with Airflow Control Systems
- Compact Size / Small Footprint
- Economical Upfront Investment

### Inovair™ 2200 Blower: Proven Centrifugal Blower Technology Provides Substantial Energy Savings

Offering the lowest cost per cfm, the Inovair 2200 Blower is compatible with a wide range of industrial airflow requirements. Utilizing advanced centrifugal compressor technologies, Inovair blowers can produce substantial energy savings relative to positive displacement blowers, **typically in the 10 to 35% range**. Inovair Blowers and Complete Systems feature a small installation footprint and compact size, making them ideal for both new build and replacement compressor fitments.

The Inovair 2200 blower is designed, manufactured and serviced in Kansas City and is available now. Call today for more information.

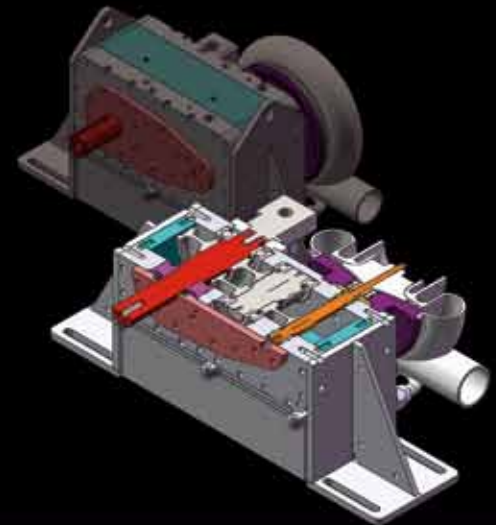

**η = Efficiency™**

# ***What is Centrifugal Compression?***

Centrifugal compression, at its most basic level, is accomplished in two steps. First, air is aerodynamically accelerated to a high velocity, creating dynamic pressure. Second, the air goes through a diffusion process where its velocity is reduced and the dynamic pressure converted to static pressure.

For clarity sake, dynamic pressure is felt while flying a kite. The force exerted on the string is, in part, a by-product of the wind's velocity. This force is felt even though the static pressure of the air surrounding the kite (also known as barometric pressure) is the same as that surrounding the person holding the string. Static pressure is a more common term and is easily measured with a pressure gauge such as you would measure the tire pressure on your car. Diffusion most commonly occurs by increasing the passage area the air is traveling through.

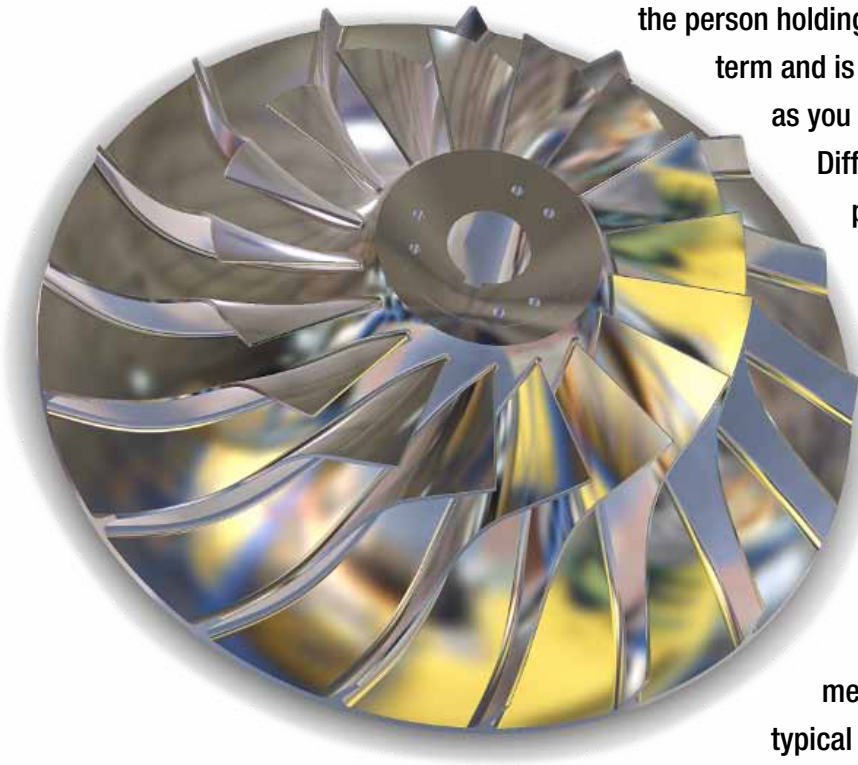

Aerodynamic compression is used throughout various industries because these systems are very energy efficient, have fewer rubbing parts and allow the designer to optimize the flow vs. pressure relationship for a specific application. The centrifugal design is also considerably more forgiving to media ingestion due to the mechanical differences when compared to a typical positive displacement system.

**$\eta$  = Efficiency™**

**inovair™**  
Dynamic Efficiency